



COMBINE
 MOUNTING RAILS
 TO CREATE LONGER
 INSTALLS

BT8390-EXT

SYSTEM X™

RAIL EXTENSION KIT



The BT8390-EXT is an extension kit designed to extend rails to a desired length, perfect for creating large menu boards, video walls and other digital signage installations. The kit consists of 6 steel joining bars which fit into the channels on either side of the mounting rail. The joining bars are then held firmly together using the internal grub screws. The underside of the joining bars feature spring-loaded bearings which allows the bars to move easily into their fixed position.

SPECIFICATION

Joining Bars per kit	6
Dimensions (per joining bar)	L:180mm W:12mm D:8mm
Colour	Zinc

FEATURES

- Combines BT8390 Horizontal Mounting Rails to create longer lengths
- Joining bars are made from 6mm thick steel
- Spring-loaded bearings allow the joining bars to move easily into position
- Rails slide easily into position to create a seamless join
- High-end aesthetic quality
- Securely lock the mounting rails in place using the internal grub screws
- Seamless finish maintains the premium quality of the product
- All mounting hardware included
- 6 joining bars supplied with each kit



SYSTEM X™



Rails slide easily into position to create a seamless join



Securely lock the mounting rails in place using the locking bar's internal grub screws

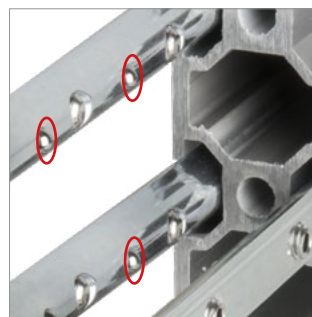

Spring-loaded bearings allow the joining bars to move easily into position



Seamless finish maintains the premium quality of the product

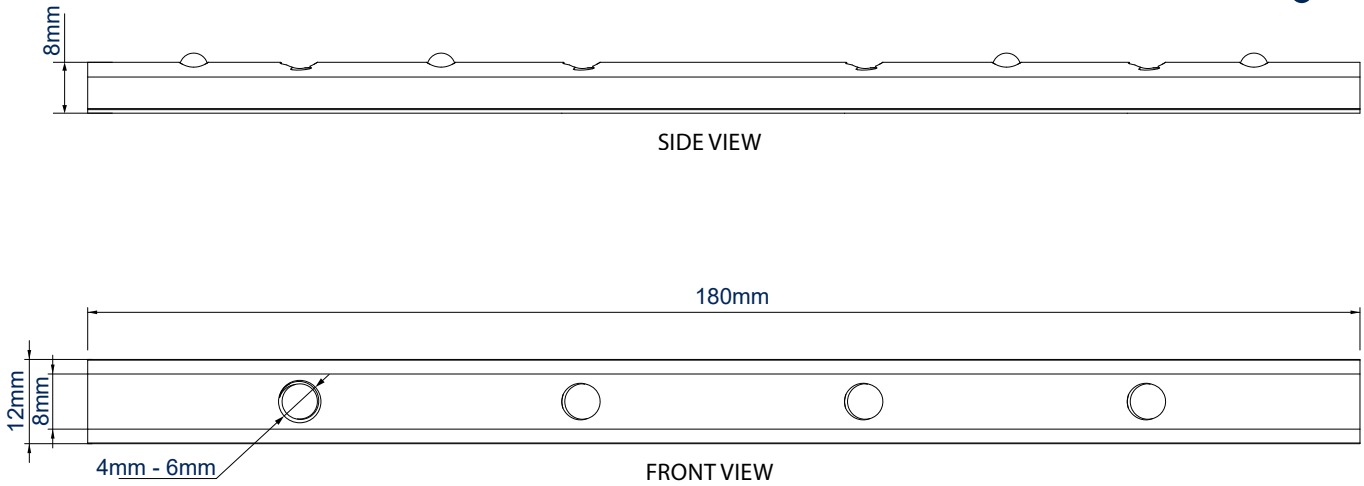

REQUIRED BT8390-EXT ASSEMBLY

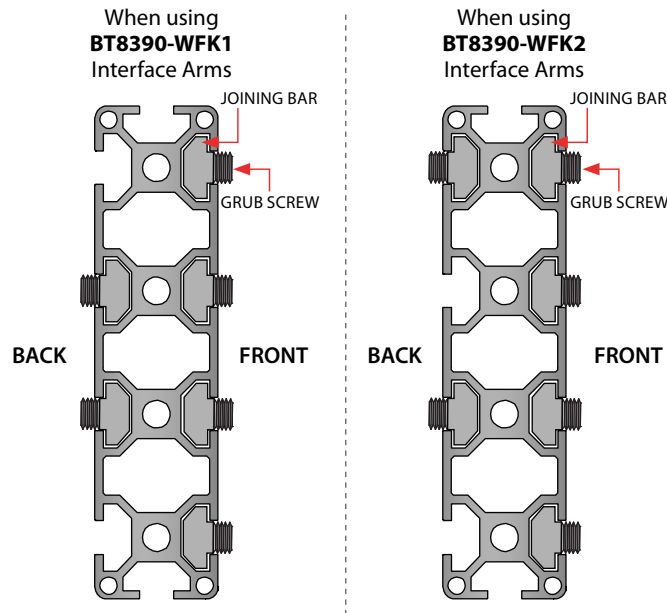

PACKING INFORMATION

COLOUR:	ORDER REF:	EAN CODE:	MASTER CARTON QTY:	INNER CARTON QTY:	MASTER CARTON WEIGHT:	MASTER CARTON CUBE:
Silver	BT8390-EXT/S	5019318501296	1	0	0.52kg	0.001cbm

ORIGINAL DESIGNS BY B-TECH AV MOUNTS - REGISTERED DESIGNS & PATENTS APPLY

ACCESSORIES AND RELATED PRODUCTS



BT8390-030/050/070/150/175/200
Wall Fixing Kits fit directly to **Mounting Rails** to create a huge range of wall mounting solutions.



BT8380-060/180
Vertical Columns are used to create a vertical support for many System X installations



BT8390-WFK1
BT8390-WFK1s are designed for wall mounting installations using fixed or tilt arms.



BT8390-WFK2
BT8390-WFK2s are designed for wall mounting installations using Micro Adjustment or Pop-Out Arms.

© 2019 B-Tech Av Mounts. All rights reserved. This information is for informational purposes only and does not constitute an offer of any product. B-Tech Av Mounts is not responsible for any damage or loss of data caused by improper or unauthorized use of its products. Any reproduction or transmission of any part of this specification is strictly prohibited unless prior written permission has been granted by B-Tech Av Mounts Manufacturing Ltd. SS-V1-BT8390-EXT-020819