

BEALE

Xpress

BS650, BXC650, BXC650D, BXC651, BXC800,
BXC801, BXCA650, BXCA651 In Ceiling Speakers;
BXCS650, BXCS800 In Ceiling Subwoofer

Installation Guide



XPECT MORE

POWERED BY:
SonicVortex
TECHNOLOGY

Introduction

Congratulations and thank you for purchasing Xpress In Ceiling speakers and subwoofers with Sonic Vortex®.

Sonic Vortex incorporates a compact Integrated Transmission Line Ported Enclosure. Most In Ceiling speakers do not utilize a back box, even fewer have an enclosure, and only a Sonic Vortex speaker has an Integrated Transmission Line Ported Enclosure. Without something behind the speaker driver the music not only plays into the room, but also bleeds into adjoining rooms such as the attic or an occupied room. The bleed negatively affects performance, and sound consistency.

Sonic Vortex changes all that with its Transmission Line Ported Enclosure that directs all of the sound from the speaker driver into the room it is intend to be in, so you get to enjoy your speakers without disturbing the rest of the house. Great bass response, stereo image, and big sound that you can't get with any other In Ceiling speaker.

Xpress In Ceiling speakers and subwoofers install with ease using the 'dog' mounting system and magnetic bezelless grilles for fast, clean installations.

Please follow the instructions in this manual to assure proper installation and to achieve the full performance and satisfaction you would expect from Xpress.

Speaker Placement

When installing in ceiling speakers or subs, (or in ceiling anything for that matter) it is always a good idea to find out what is in the ceiling before cutting holes. Be aware of the location of plumbing, electrical and structural elements that may affect speaker placement.

Stereo

It is also a good idea to locate stereo speakers so they are centered to the main listening position in which the user/s will normally be located. Whenever possible, try to position the left and right speakers at the same distance from each other as they are from the main listening position.

Subwoofer

Subwoofers are omni-directional so placement of in ceiling subs is somewhat less critical, but placement can be affected (good and bad) by corners and walls, so try to find a location that will be somewhat unaffected by placement.

Angled

If using the 'Angled In' speakers, be sure to position them so the speakers are facing into the room and directed toward the main listening position.

Surround

Locate surround speakers according to the recommendations in the surround processor's owner's manual

Installation

SPEAKER WIRE

Pull one run of 16AWG stranded speaker wire from the amplifier location to each speaker location. If in pre-wire, while the walls are open and it's easy, pull extra wire to any location that may be desirable to add speakers at a later date. Leave extra length of wire on each end to allow making connections and installing/removing speakers.

Use the chart below to determine the proper gauge of wire, based upon wire length from the amp to the speakers. If using volume controls, include the total length from the amp to the volume control and then to the speakers.

SPEAKER WIRE GAUGE TABLE	
SPEAKER WIRE LENGTH	SPEAKER WIRE GAUGE
150' (46m)	16AWG
400' (122m)	14AWG

NEW CONSTRUCTION

Xpress speaker installation can be simplified by using an Xpress new construction EZBracket®, (sold separately; visit www.bealexpress.com for additional information). This is installed prior to drywall installation and allows for precise speaker placement and simplifies the final installation of the speaker.

EXISTING CONSTRUCTION

Speaker wire must be run from the equipment or volume control location to each potential speaker location.

- Choose a location for each speaker that is free of obstructions created by joists, HVAC duct-work, electrical wire runs, plumbing or anything else that might not allow for the depth of the speaker or create interference or noise.

Installation

- Once you have determined your locations, use a pencil to mark the hole to cut out for the speaker using the supplied template. Don't forget to allow for the size of the speaker bezel if you are installing the speaker near a sidewall or other item that could become an obstacle.

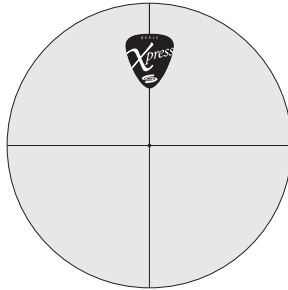

- If you are unsure of potential obstacles, carefully cut your holes using an angle to the inside of the cutout area. This will allow you to "plug" the hole easily if needed. If the area is clear and is a good location for the speaker, go ahead and cut the edges of the opening at 90 degrees to accommodate the speaker diameter.

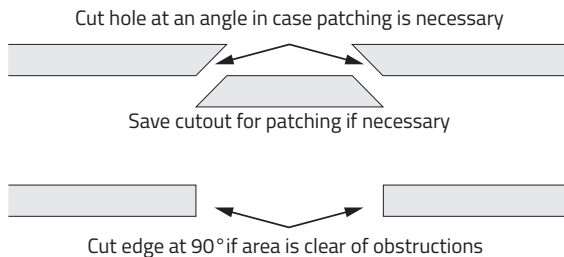

- Strip the insulation on each conductor approximately 1/2" (12.7mm) and insert to the speaker terminals. Ensure that there are no stray strands of wire protruding from the connectors that can cause shorts. Observe proper polarity (+ to + and - to - for each speaker and at the amplifier) and that surround channels are properly positioned and connected, if used.

Installation

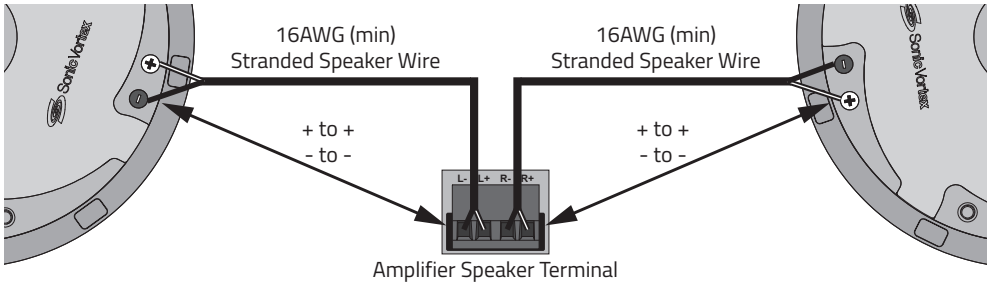

- With the 'dogs' flush to the side of the speaker, insert the speaker into the cutout and tighten each of the four screws for the speakers' dogs, enough to clamp the speaker to the drywall. Do not overtighten.

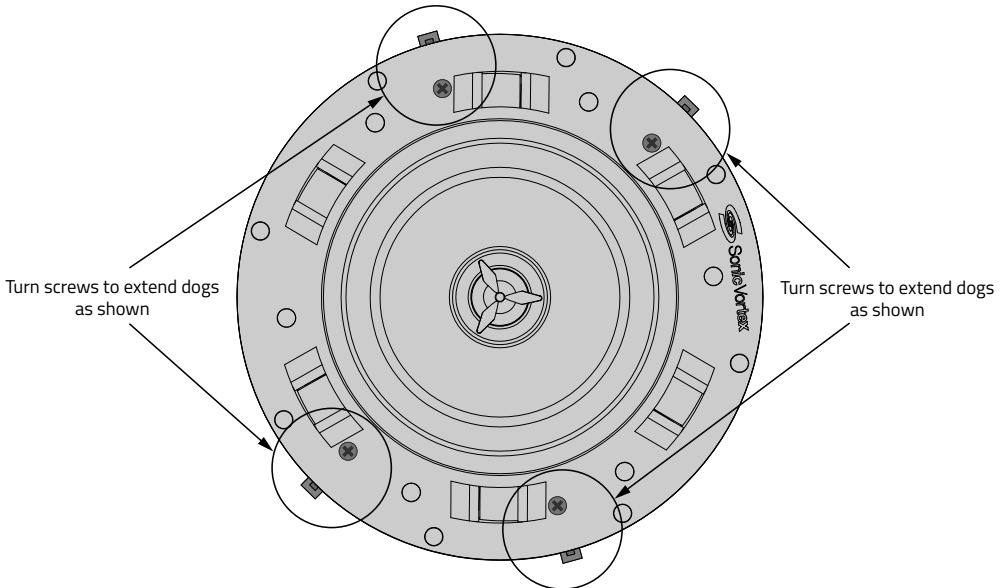

PAINING

The grille may be painted, but go as light as possible to not to clog the fine holes with paint. Only paint grilles when they have been removed from the speakers and be sure to remove the cloth on the backside of the grille before painting. If the cloth is not removed for painting, it will absorb the paint and clog the grille, significantly affecting the sound...and not in a good way. (We have taken great effort to eliminate any 'color' from the sound of our speakers, so let's try to keep it that way...OK?)

Troubleshooting

Xpress speakers are designed to function trouble-free. Most problems that occur are due to simple issues. If you have trouble, please check the list of simple fixes below.

SPEAKER TROUBLESHOOTING	
PROBLEM	SOLUTION
NO SOUND	Verify that there is audio from the source selected. Select another source if necessary.
	Ensure that the amplifier is turned on and connected properly.
	Check any connections at other devices, such as a volume control. Temporarily bypass the control if needed.
	Check wire connections at each speaker not producing sound for good contact to bare wire, not wire insulation.

Specifications

6.5" IN CEILING

BS650 6.5" In Ceiling 2-way

- 6.5" Polypropylene woofer
- 1" silk dome tweeter
- Butyl rubber surround
- Pivoting tweeter
- Speaker Weight: 2.69lbs (1.22kg)
- Cutout: 8.4" 214mm
- Diameter 9.4" 239mm
- Depth 3.3" 84mm
- Power Handling: 5-90W
- Impedance: 8Ω
- Installed Frequency response: 60 Hz - 22 kHz
- Sensitivity: 91db
- Grille: Magnetic Bezelless; White - Paintable
- Connector Type: Push terminals
- EZBracket Size: F

BXC650 6.5" In Ceiling 2-way

- 6.5" Polypropylene woofer
- 1" silk dome tweeter
- Butyl rubber surround
- Coaxial tweeter design
- Sonic Vortex ported transmission line enclosure
- Speaker Weight: 7.10 lbs
- Cutout: 8.4" 214mm
- Diameter 9.4" 239mm
- Depth 6.8" 172mm
- Power Handling: 5-120W
- Impedance: 8Ω
- Installed Frequency response: 48 Hz - 20 kHz
- Sensitivity: 91db
- Grille: Magnetic Bezelless; White - Paintable
- Connector Type: Gold Spring Push Terminal
- EZBracket Size: F

BXC650D 6.5" Dual Voice Coil In Ceiling

- 6.5" Polypropylene woofer
- 1" Dual voice coil silk dome tweeter
- Butyl rubber surround
- Coaxial tweeter design
- Sonic Vortex ported transmission line enclosure
- Speaker Weight: 7.10 lbs
- Cutout: 8.4" 214mm
- Diameter 9.4" 239mm
- Depth 6.8" 172mm
- Power Handling: 5-120W
- Impedance: 8Ω
- Installed Frequency response: 50 Hz - 20 kHz
- Sensitivity: 91db
- Grille: Magnetic Bezelless; White - Paintable
- Connector Type: 4 Pin Terminal
- EZBracket Size: F

Specifications

BXC651 6.5" In Ceiling 2-way

- 6.5" Ribbed injected polypropylene woofer
- 1" Aluminum dome tweeter
- Butyl rubber surround
- Coaxial tweeter design
- Sonic Vortex ported transmission line enclosure
- Speaker Weight: 7.10 lbs
- Cutout: 8.4" 214mm
- Diameter 9.4" 239mm
- Depth 6.8" 172mm
- Power Handling: 5-120W
- Impedance: 8 Ω
- Installed Frequency response: 46 Hz - 22 kHz
- Sensitivity: 91db
- Grille: Magnetic Bezelless; White - Paintable
- Connector Type: Gold Spring Push Terminal
- EZBracket Size: F

8" IN CEILING

BXC800 8" In Ceiling 2-way

- 8" Polypropylene woofer
- 1" Silk dome tweeter
- Butyl rubber surround
- Coaxial tweeter design
- Sonic Vortex ported transmission line enclosure
- Speaker Weight: 8.38 lbs
- Cutout: 10.3" 261.5mm
- Diameter 11.3" 284mm
- Depth 8.6" 219.5mm
- Power Handling: 5-120W
- Impedance: 8 Ω
- Installed Frequency response: 40 Hz - 20 kHz
- Sensitivity: 91db
- Grille: Magnetic Bezelless; White - Paintable
- Connector Type: Gold Spring Push Terminal
- EZBracket Size: B

BXC801 8" In Ceiling 2-way

- 8" Ribbed injected polypropylene woofer
- 1" Aluminum dome tweeter
- Butyl rubber surround
- Coaxial tweeter design
- Sonic Vortex ported transmission line enclosure
- Speaker Weight: 8.38 lbs
- Cutout: 10.3" 261.5mm
- Diameter 11.3" 284mm
- Depth 8.6" 219.5mm
- Power Handling: 5-120W
- Impedance: 8 Ω
- Installed Frequency response: 38 Hz - 22 kHz
- Sensitivity: 91db
- Grille: Magnetic Bezelless; White - Paintable
- Connector Type: Gold Spring Push Terminal
- EZBracket Size: B

Specifications

6.5" ANGLED IN CEILING

BXCA650 6.5" Angled In Ceiling 2-way

- 6.5 Polypropylene woofer
- 1" silk dome tweeter
- Butyl rubber surround
- Coaxial tweeter design
- 15 degree angled woofer
- Sonic Vortex ported transmission line enclosure
- Speaker Weight: 6.97 lbs
- Carton Weight: 7.57 lbs
- Cutout: 8.4" 214mm
- Diameter 9.4" 239mm
- Depth 6.8" 172mm
- Power Handling: 5-120W
- Impedance: 8Ω
- Installed Frequency response: 50 Hz - 20 kHz
- Sensitivity: 91db
- Grille: Magnetic Bezelless; White - Paintable
- Connector Type: Gold Spring Push Terminal
- EZBracket Size: F

BXCA651 6.5" Angled In Ceiling 2-way

- 6.5" Ribbed injected polypropylene woofer
- 1" Aluminum dome tweeter
- Butyl rubber surround
- Coaxial tweeter design
- 15 degree angled woofer
- Sonic Vortex ported transmission line enclosure
- Speaker Weight: 6.97 lbs
- Cutout: 8.4" 214mm
- Diameter 9.4" 239mm
- Depth 6.8" 172mm
- Power Handling: 5-120W
- Impedance: 8Ω
- Installed Frequency response: 48 Hz - 22 kHz
- Sensitivity: 91db
- Grille: Magnetic Bezelless; White - Paintable
- Connector Type: Gold Spring Push Terminal
- EZBracket Size: F

Specifications

6.5" IN CEILING SUBWOOFER

BXCS650 6.5" In Ceiling Subwoofer

- 6.5" Fiberglass woofer
- Butyl Rubber Surround
- Sonic Vortex ported transmission line enclosure
- Speaker Weight: 7.10 lbs
- Cutout: 8.4" 214mm
- Diameter 9.4" 239mm
- Depth 6.8" 172mm
- Power Handling: 5-200W
- Impedance: 4Ω
- Installed Frequency response: 40 Hz - 300 Hz
- Sensitivity: 90db
- Grille: Magnetic Bezelleless; White - Paintable
- Connector Type: Gold Spring Push Terminal
- EZBracket Size: F

8" IN CEILING SUBWOOFER

BXCS800 8" In Ceiling Subwoofer

- 8" Fiberglass woofer
- Butyl Rubber Surround
- Sonic Vortex ported transmission line enclosure
- Speaker Weight: 8.38 lbs
- Cutout: 10.3" 261.5mm
- Diameter 11.3" 284mm
- Depth 8.6" 219.5mm
- Power Handling: 5-200W
- Impedance: 4Ω
- Installed Frequency response: 36 Hz - 300 Hz
- Sensitivity: 90db
- Grille: Magnetic Bezelleless; White - Paintable
- Connector Type: Gold Spring Push Terminal
- EZ bracket Size: B

Limited Warranty

All in-wall, in-ceiling, outdoor speakers, volume controls, and freestanding loudspeakers have a Lifetime Limited Warranty. This warranty includes lifetime parts and repair on components. Powered subwoofers and Xpress amplifiers have a two (2) year limited warranty. This warranty includes two (2) year parts and repair labor on components. Xpress obligation under this warranty is limited to repairing or replacing any component found defective in material or workmanship under normal conditions of use. This warranty shall not apply to products which have been abused, modified, disassembled, or repaired by anyone other than Xpress or one of its appointed service centers. Products to be repaired under this warranty must be returned to the factory or designated service center with all transportation and insurance charges pre-paid.

IMPORTANT: This warranty is ONLY valid if the product is purchased through a Certified Xpress Dealer. Proof of purchase may be required.

Note: It is the policy of Xpress to continuously incorporate improvements into our products. All specifications, warranty terms, and prices are subject to change without notice.



XPECT MORE

Beale Xpress
122 Gayoso Street, Suite 101
Memphis, TN 38103
Phone: 844.489.2700 Fax: 901.205.0900
www.bealexpress.com
©2015 Beale Street Audio

BXCICIG073115 Rev 1