

BEALE

Xpress

IA-1250

12 Channel x 50W Amplifier

User Guide



XPECT MORE

Important Safety Instructions



CAUTION: To reduce the risk of electric shock, do not remove cover (or back). No user-serviceable parts inside. Refer servicing to qualified service personnel.

▪ Explanation of Graphical Symbols



The lightning flash with arrowhead symbol, within an equilateral triangle, is intended to alert you to the presence of uninsulated "dangerous voltage" within the product's enclosure that may be of sufficient magnitude to constitute a risk of electric shock to persons.



The exclamation point within an equilateral triangle is intended to alert you to the presence of important operating and maintenance (servicing) instructions in the literature accompanying the product.

APPLICABLE FOR USA, CANADA OR WHERE APPROVED FOR USAGE

CAUTION: TO PREVENT ELECTRIC SHOCK, MATCH WIDE BLADE PLUG TO WIDE SLOT, INSERT FULLY.

ATTENTION: POUR EVITER LES CHOCS ELECTRIQUES, INTRODUIRE LA LAME LA PLUS LARGE DE LA FICHE DANS LA BORNE CORRESPONDANTE DE LA PRISE ET POUSSER JUSQU'AU FOND.

1. Read these instructions.
2. Keep these instructions.
3. Heed all warnings.
4. Follow all instructions.
5. Do not use this apparatus near water.
6. Clean only with a dry cloth.
7. Do not block any ventilation openings. Install in accordance with the manufacturer's instructions.
8. Do not install near any heat sources such as radiators, heat registers, stoves, or other apparatus (including amplifiers) that produce heat.
9. Do not defeat the safety purpose of the polarized or grounding-type plug. A polarized plug has two blades with one wider than the other. A grounding-type plug has two blades and a third grounding prong. The wide blade or the third prong are provided for your safety. If the provided plug does not fit into your outlet, consult an electrician for replacement of the obsolete outlet.
10. Protect the power cord from being walked on or pinched particularly at plugs, convenience receptacles, and the point where they exit from the apparatus.
11. Only use attachments/accessories specified by the manufacturer.
12. Use only with the cart, stand, tripod, bracket, or table specified by the manufacturer, or sold with the apparatus. When a cart is used, use caution when moving the cart/apparatus combination to avoid injury from tip-over.

PORTABLE CART WARNING



13. Unplug this apparatus during lightning storms or when unused for long periods of time.
14. Refer all servicing to qualified service personnel. Servicing is required when the apparatus has been damaged in any way, such as power-supply cord or plug is damaged, liquid has been spilled or objects have fallen into the apparatus, the apparatus has been exposed to rain or moisture, does not operate normally, or has been dropped.
15. The apparatus shall not be exposed to dripping or splashing and that no objects filled with liquids, such as vases, shall be placed on the apparatus.
16. **CAUTION:** Servicing instructions are for use by qualified service personnel only. To reduce the risk of electric shock, do not perform any servicing other than that contained in the operating instructions unless you are qualified to do so.
17. **WARNING:** To reduce the risk of fire or electric shock, do not expose this apparatus to rain or moisture.

Table of Contents

Important Safety Instructions	2
Table of Contents	3
Introduction.....	4
Features.....	5
What's Included	5
Front Panel Features	6
Rear Panel Features.....	7
IR Remote Control.....	9
Installation	10
Wiring Infrastructure.....	11
Speaker Wire	11
Multi-zone Audio (4/8Ω).....	11
Multi-room Audio - Stereo or Bridged (4/8Ω).....	11
70V/100V.....	11
Connections.....	12
Speaker Connections	12
Bridged 8Ω	12
4Ω/8Ω	12
70V/100V.....	13
Audio Connections	14
Zone Line IN.....	14
Audio Bus IN	14
Audio Bus OUT	14
Control Connections.....	15
Zone IR IN	15
Zone Mute	16
Zone Status OUT	16
Zone Line/Bus Trigger IN	16
Master Control IN	17
Master Control OUT	17
RS232 I/O	17
Settings	18
70V/100V High Voltage Speaker Output	18
8Ω/4Ω-70V/100V Zone Setting.....	18
Stereo/Bridged Zone Setting	18
Limiter.....	18
Remote Bypass	19
Voltage Select/Fuse.....	19
Operation.....	21
Voltage Controlled.....	21
IR Controlled.....	21
RS232 Controlled.....	22
RS232 Commands.....	23
RS232 Queries.....	25
RS232 Settings.....	27
Specifications	29
Limited Warranty	30

Introduction

Congratulations and thank you for purchasing the Beale Street Xpress IA-1250 12 Channel Amplifier.

The IA-1250 is, at its core, a twelve channel audio distribution amp. Snore...

That's why the IA-1250 does so much other stuff!!! OK. Yes, it is a twelve channel audio distribution amp that can be configured for six stereo 4Ω/8Ω zones (30W/channel @ 8Ω; 50W/channel @ 4Ω); but it can also be configured for six stereo 70/100V zones (30W/channel); or three high powered bridged zones (100W @ 8Ω). By the way, the IA-1250 can be configured for any combination of stereo 4Ω/8Ω, 8Ω bridged and 70/100V zones all at the same time! That's some stuff, right?

But there's more...each zone can be controlled via IR or RS232 for ON/OFF, Input, Volume/Mute, Treble/Bass and Left/Right Balance. The RS232 section is bi-directional with easy to configure command structure. IA-1250 can be configured to automatically send zone status updates or respond to queries to confirm zone status and settings. Commands for volume, treble/bass and balance can be specific values or step commands depending upon the control application.

The IA-1250 has an Audio Bus IN that can be manually selected by IR commands, RS232 commands or voltage trigger. The voltage trigger will switch a zone to the Audio Bus IN as long as there is voltage present on the zone Line/Bus Trigger IN. When the voltage is cut, the zone automatically switches back to the zone Line IN. Great for momentary switching to an audio page on the Bus IN!

Each zone has a Mute Trigger IN that will mute zone audio when voltage is present on the Mute Trigger IN. When the voltage is cut, the zone audio output resumes.

Each zone has a 12VDC Status or Control OUT that can be used to activate a zone specific volatge controlled device or otherwise indicate zone ON/OFF status.

Each zone has a -20dB audio limiter to prevent incidental peaks from becoming irrevocable problems.

The IA-1250 features a Remote Bypass switch that allows/blocks IR and RS232 from select zones for zones that are intended to be set and not messed with.

Finally, the IA-1250 can has a 110~120V/220~240V select switch allowing it to be used just about anywhere there is AC Voltage.

What? Yes of course it's rack mountable and comes with removable rack ears.

The Beale Street Xpress IA-1250 12 channel x 50W audio distribution amp...ready for anything...anywhere.

Please read and follow the instructions in this guide to assure proper installation and maximum performance of your new Beale Street Xpress IA-1250.

Features

- Each zone can independently select a zone-specific stereo audio source or the global mono Audio Bus input (unbalanced)
- Each zone can be independently configured for stereo 4Ω/8Ω mode, high powered bridged 8Ω mode or 70V/100V mode for total flexibility within a given installation
- All zones are independently controllable via RS232, IR and voltage trigger lines
- Each zone has -20dB Audio Limiter
- Each zone has an independent mute trigger input (activated by +3 to +30V DC)
- Each zone has an individual Trigger Output (+12V DC) that corresponds to zone ON/OFF status
- Front panel features "Zone ON" and "Zone Overload" LED indicators for each zone
- Master global Control In (+3 to +30V DC) and Control Out (+12V DC)
- Detachable screw-terminal connectors for global Audio Bus IN/OUT, Zone IR IN, Zone Mute, Zone Status OUT and Zone Speaker Outputs
- Rack mountable in standard 19" rack (2U height)
- Selectable 110/220 AC voltage

What's Included

- 1 - IA-1250 Amplifier
- 1 - IR Remote
- 1 - AC Power Cord
- 1 - Owner's Manual

Front Panel Features

This is the stuff on the front panel...

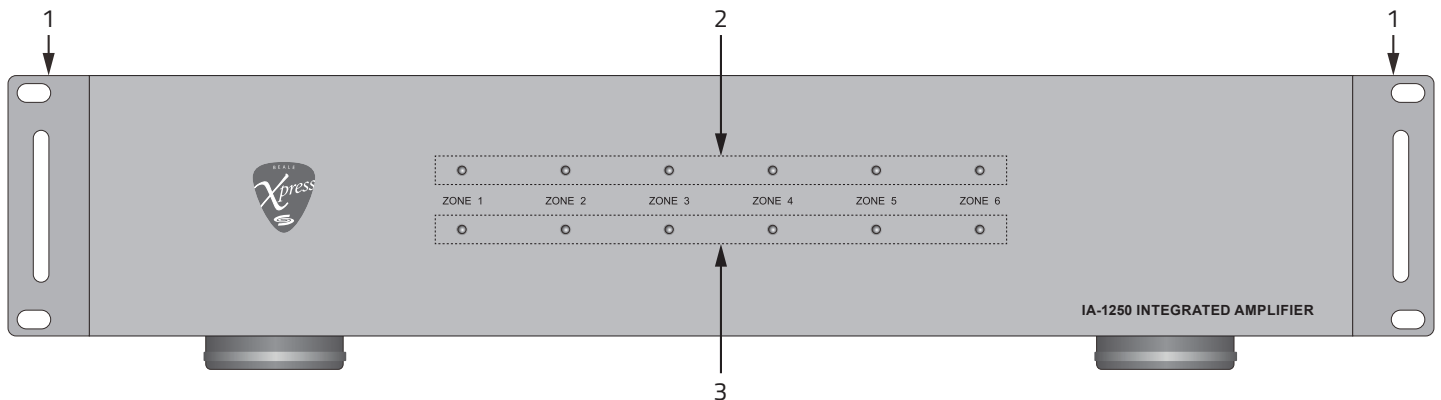

- 1. RACK EARS** - Two, optional rack ears for optional rack mounting...see where this is going? The IA-1250 is 2U rack height. If rack mounting, leave one rack space above and below for air flow. The rack ears can be removed for shelf mount if desired. (OK. So they're not necessarily on the front panel, but you can see them from here.)
- 2. PEAK OUTPUT LEDs** - Six, red LEDs indicate that the amplifier is within 5% of the maximum volume setting. This is an indication that the volume setting is approaching maximum...not an indication of the specific power output. To be safe, when this LED illuminates, back the volume off a bit to protect the amp, speakers and probably your hearing.
- 3. ZONE POWER LEDs** - Six, green LEDs illuminate solid green when a stereo zone is ON. LED turns OFF when Zone is OFF.

Rear Panel Features

This is the stuff on the rear panel...

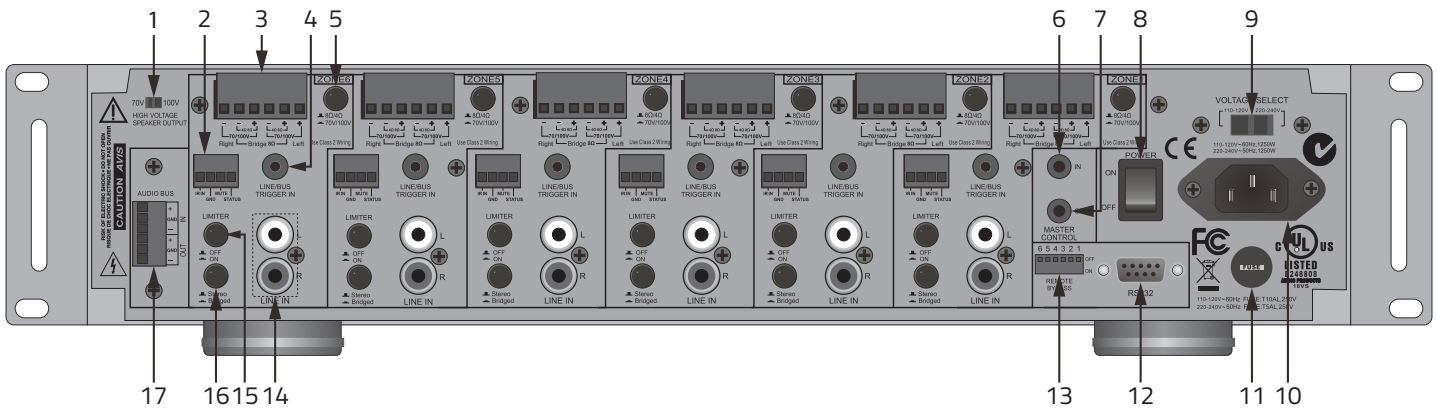

1. **SYSTEM 70/100 VOLT SELECT** - One, switch. Slide switch to select between 70V and 100V for a high-voltage audio distribution system. This setting will affect all zones in 70V/100V mode. Set for 70V when voltage select is set to 110-120VAC; Set for 100V when voltage select is set to 220-240VAC.
2. **ZONE IR, MUTE & STATUS TERMINAL** - Six, plug-in screw terminals. Provides connections for zone specific IR control, mute and status.
 - IR IN** - Connect IR IN & GND to the Emitter OUT on an Xpress IR Control system for zone IR control using the IA-1250 IR Remote.
 - Mute** - Connect to a +3 to +30VDC @1mA control voltage to mute the local zone.
 - Status** - Provides a 12VDC 1mA Control OUT to trigger zone specific voltage controlled devices.
3. **ZONE SPEAKER TERMINAL**- Six, plug-in screw terminals. Each terminal has six connections for different speaker output configurations including:
 - Bridge 8Ω** - Use indicated terminals for high output mono speaker connection. (100W @ 8Ω)
NOTE 1: 8Ω/4Ω - 70V/100V switch must be in the OUT position.
NOTE 2: The Stereo/Bridged switch must be in the IN (Bridged) position.
 - 4Ω/8Ω** - Use indicated terminals for normal stereo speaker connections. (30W @ 8Ω; 50W @ 4Ω)
NOTE 1: 8Ω/4Ω - 70V/100V switch must be in the OUT position.
NOTE 2: The Stereo/Bridged switch must be in the OUT (Stereo) position.
 - 70V/100V** - Use indicated terminals for 70V/100V stereo speaker connections. (30W @ 70V/100V)
NOTE 1: 8Ω/4Ω - 70V/100V switch must be in the IN position.
NOTE 2: 70V/100V High Voltage Speaker Output Switch must be set to proper voltage.
NOTE 3: The Stereo/Bridged switch must be in the OUT (Stereo) position.
4. **ZONE LINE/BUS TRIGGER IN**- Six, 3.5mm mini jacks. This voltage controlled input switches the zone audio input from Line IN to Audio Bus IN. When there is no voltage applied, the zone audio input is zone Line IN. When voltage is applied (+3 to +30VDC @1mA) the zone audio input will switch to Audio Bus IN.
5. **ZONE 8Ω/4Ω - 70V/100V SWITCH** - Six, push buttons. Press to select 8Ω/4Ω - 70V/100V by zone. Leave OUT to select 8Ω/4Ω, press IN to select 70V/100V.
6. **MASTER CONTROL IN** - One, 3.5mm mini jack. Connect to a +3 to +30VDC @1mA control voltage to turn the IA-1250 ON.
NOTE: Power ON/OFF switch must be in the OFF position when using this feature.

Rear Panel Features

- 7. MASTER CONTROL OUT** - One, 3.5mm mini jack. Connect to any voltage controlled device that is to be turned ON/OFF relative to IA-1250 ON/OFF Status. When any zone on the IA-1250 is ON the Master Control OUT will output 11.5VDC@1mA-10VDC@5mA. When all zones are OFF the Master Control OUT is 0.0VDC.
- 8. POWER ON/OFF SWITCH** - One, switch. Set to ON position to turn power to the amp ON. Set to OFF position to turn power to the amp OFF.
- 9. VOLTAGE SELECT SWITCH** - One, switch. Select either 110V-120V or 220V-240V as appropriate for local AC line voltage. Please confirm local voltage prior to use or making changes to the setting.
- 10. AC MAINS** - One, three-prong socket. Use the supplied 3-pin ground power cable to connect the unit to an external AC power supply.
- 11. FUSE** - One, replaceable fuse. For 110V-120V/60Hz use T10.0AL/250V fuse. For 220V-240V/50Hz use T5.0AL/250V fuse.
- 12. RS232 TERMINAL** - One, DB9F terminal. Connect to an automation system or other controller for two-way communication with and control of the IA-1250.
- 13. REMOTE BYPASS** - One, six position DIP switch. Set to OFF to allow IR/RS232 control of the selected zone. Set to ON to block IR/RS232 control of the selected zone.
- 14. ZONE LINE IN** - Twelve, RCA jacks. Connect to the L & R line level OUTs on an audio source that is to be dedicated to the local zone.
- 15. ZONE AUDIO LIMITER** - Six, push buttons. Press to activates a -20dB input limiter, for both channels, to help reduce the level of accidental audio peaks and clipping distortion by zone. Leave in the OUT position to pass audio through unprocessed, press IN to activate the input limiter.
- 16. STEREO/BRIDGED** - Six, push buttons. Sets zone amplifier output to stereo/bridge mode. **This switch works in conjunction with the zone speaker connections and 8Ω/4Ω - 70V/100V switch position. Please see sections: Zone Speaker Terminal and 8Ω/4Ω - 70V/100V Switch, previous, for important information.**
 - Stereo** - For stereo signals, leave switch in the OUT (Stereo) position. This applies to all connections in the 8Ω/4Ω and 70V/100V configurations.
 - Bridged** - ONLY press this button when using the BRIDGE 8Ω connections in a given zone.
 - CAUTION: In Bridged mode, the amplifier will encounter a load that is about one half of its actual value. A 4Ω load would therefore be 2Ω to a bridged amp and if the amplifier isn't designed to run safely into such a low impedance (which the IA-1250 is not) damage may occur to the amplifier. DO NOT CONNECT A 70V SPEAKER CIRCUIT WHILE IN BRIDGE MODE. The output will be 140V, well beyond spec for a 100V system. Any damage to the amplifier caused by this configuration is not covered under warranty.**
- 17. AUDIO BUS** - One, plug-in screw terminal. Mono, unbalanced input. This input will send the Audio IN signal to all zones switched to Bus using the Line/Bus Trigger IN. It will also send the Bus Audio IN signal to another IA-1250 via the Audio Bus OUT.

IR Remote Control

The IA-1250 IR Remote Control, believe it or not, controls the IA-1250. Actually, it controls the individual zones on the IA-1250, and will more than likely be used to program some sort of programmable, integrated IR remote, zone control system or other IR routing device.

All zones are configured for the same codes, so use of a multi-zone controller or IR router will be necessary for centralized control of the individual zones. Local zone control can be easily accommodated with a local IR receiver, (we make those...please visit www.bealexpress.com for additional information.) and an IR Remote.

- 1. IR LED** - One, high-output IR LED. The IR LED flashes invisible (infrared) light pulses that are the control codes for the IA-1250. The LED must be pointed at an IR receiver (we make those...oh...that's right...we already mentioned that) that is connected to an IA-1250 Zone IR IN.
- 2. MUTE** - With audio playing in a zone, press this button to mute the zone audio output. Press again to un-mute.
- 3. BUS** - Press this button to select the audio source playing through the Audio Bus IN.
- 4. LINE** - Press this button to select the audio source playing through the local zone Line IN.
- 5. TREBLE/BASS** - Press the Treble +/- buttons to increase/decrease the accent of high frequencies in the zone audio output. Press the Bass +/- buttons to increase/decrease the accent of low frequencies in the zone audio output. Season to taste.
NOTE: Reset to flat requires issuing an RS232 command to the zone via the RS232 terminal. See sections: RS232 Commands and IA-1250 Treble/Bass Settings for additional information.
- 6. VOLUME** - Press the Volume + button to increase zone audio output. Press the Volume - button to decrease zone audio output.
- 7. BALANCE L/R** - Press the Balance L button to increase volume in the left speaker relative to the right speaker. Press the Balance R button to increase volume in the right speaker relative to the left speaker.
NOTE: Reset to center default requires issuing an RS232 command to the zone via the RS232 terminal. See sections: RS232 Commands and IA-1250 Left/Right Balance Settings for additional information.
- 8. POWER** - Yeah...yeah...this button should have been listed first...press this button to turn the local zone ON. Press again to turn the local zone OFF.
- 9. BEALE STREET XPRESS LOGO** - No function specific to the remote, but we like the guitar pick shape, fancy script Xpress and Sonic Vortex symbol, so we just thought we'd mention it.

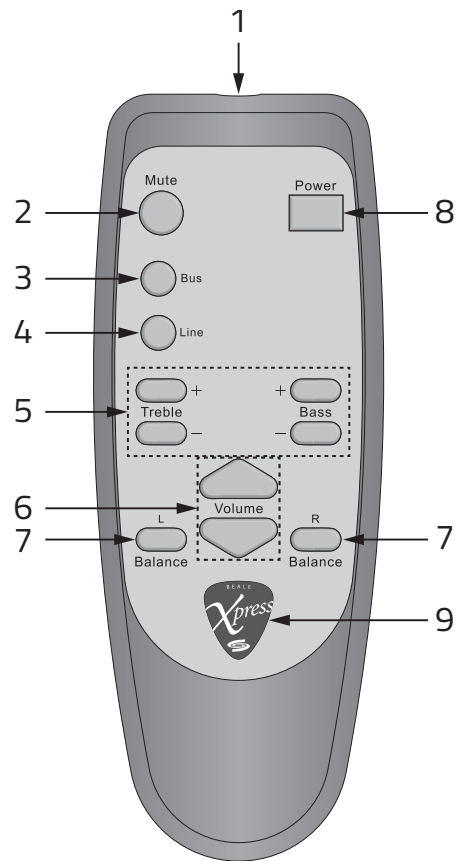

Installation

Here's a few things to consider when installing the IA-1250...

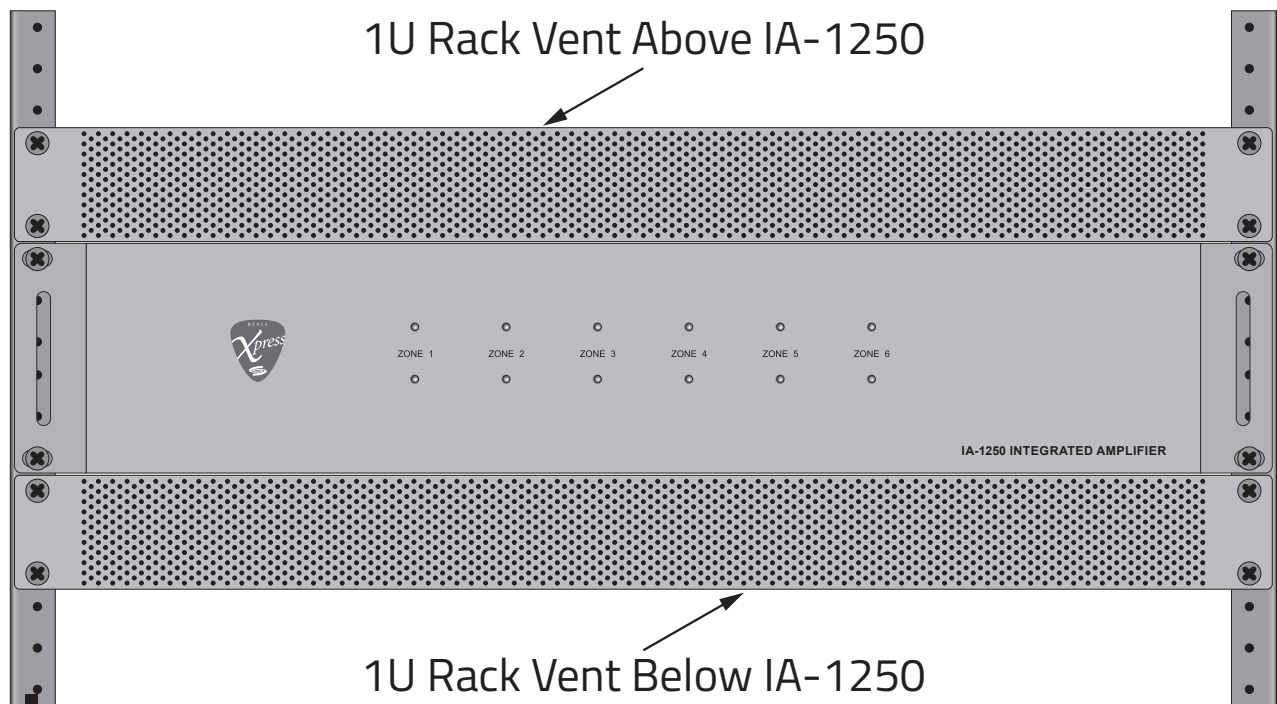

1. The IA-1250 is convection cooled. It depends on the natural free flow of air up through the slot perforations in the bottom plate, over the internal heat dissipating fins, then out the top cover, for adequate cooling.
2. The IA-1250 is designed for mounting into standard 19" (483mm) racks or on flat horizontal surfaces.
3. If mounted in an equipment cabinet or other confining location, allow at least 2 inches of space above the top cover. Be sure there are large openings in the shelf below the unit and in the cabinet to allow the entry of cool air and the escape of warm air.
4. If the cabinet contains other heat generating components or several IA-1250's are being used, be sure to provide adequate ventilation to dissipate heat the units can generate.
5. Use fans (quiet, boxer type), if necessary, to ensure a constant flow of air through the IA-1250's and the other heat generating components.
6. When installing the IA-1250 in a rack, please use racks that feature a rear support provision. Adding a single RU (Rack Unit) vent above and below the IA-1250 will improve convection in heavy use applications. [One Rack Unit size = 1-3/4" (44.5mm) in height]. Also try to mount the amplifier(s) at the top of the rack so heat dissipation does not affect other devices.
7. Be sure to leave adequate space for large bundles of wire and dress them in such a manner that does not block airflow. Leave enough 'play' in the wires for making connections should the system require service.

Wiring Infrastructure

Now for a few simple guidelines on wiring...

Speaker Wire

The IA-1250 is a flexible multi-channel amplifier capable of many different applications. The application for a given system, or even different amp configurations for different zones in a single system can create different requirements for speaker wire runs. Please review the information below and apply these guidelines to your particular application(s).

MULTI-ZONE AUDIO (4/8Ω)

If the IA-1250 is being used with a multi-zone preamp/controller then pull the home-runs directly from the speaker locations or speaker terminal plates to the amplifier location. Use quality stranded speaker wire based upon the 4/8Ω Speaker Wire Gauge Table below.

MULTI-ROOM AUDIO - STEREO OR BRIDGED (4/8Ω)

If the amp is being used to distribute audio from the IA-1250 Zone Line INs or Audio Bus IN, to different rooms with 4/8Ω Speakers, individual room volume controls (or an IR control system) will be needed. (Please visit www.bealexpress.com for additional information.) In this application pull speaker wire from each speaker to the volume control location in each room and then home-runs from each volume control to the amplifier location. Use quality stranded speaker wire based upon the 4/8Ω Speaker Wire Gauge Table below.

4/8Ω SPEAKER WIRE GAUGE	
SPEAKER WIRE LENGTH	SPEAKER WIRE GAUGE
150' (46m)	16 AWG
400' (122m)	14 AWG
1000' (305m)	12 AWG

70V/100V

If the amp is being used to distribute 70V/100V audio, pull distribution lines (each distribution line is a wire pair) in a daisy-chain pattern, (amp to first speaker, first speaker to second speaker, second speaker to third speaker, etc.) If distributing stereo, pull two distribution lines (two pair) to each speaker location in a daisy chain from the amp location. Use quality stranded speaker wire based upon the 70V Speaker Wire Gauge Table below.

70V SPEAKER WIRE GAUGE (30W Zone Output)	
SPEAKER WIRE LENGTH	SPEAKER WIRE GAUGE
350' (106m)	24 AWG
550' (167m)	22 AWG
900' (274m)	20 AWG
1400' (426m)	18AWG
2300' (701m)	16AWG

Connections

Speaker Connections

The IA-1250 has three amplifier modes for zone speaker connections. Bridged 8Ω, 4/8Ω Stereo and 70V/100V. Any mix of amplifier modes is allowable in different zones...as long as they are configured correctly. In all cases, connect speakers after all switch changes have been made to protect the amp and speakers!

BRIDGED 8Ω

Bridging a zone amp creates an 8Ω, 110 Watt mono amplifier. You will need to use two bridged zones for stereo.

1. **Stereo/Bridged Switch** - Set to the Bridged position.
2. **8Ω/4Ω-70V/100V Switch** - Set to the 8Ω/4Ω position.
3. **Speaker Connections** - Connect the wire from the speaker - terminal to the Bridge 8Ω - terminal as shown in: **Bridged 8Ω Connection**. Connect the wire from the speaker + terminal to the Bridge 8Ω + terminal as shown in: **Bridged 8Ω Connection**.
4. **Zone Line IN** - Connect the source left channel OUT to the left channel Line IN on the LOWER NUMBERED bridged zone. Connect the source right channel OUT to the left channel Line IN on the HIGHER NUMBERED bridged zone.

4Ω/8Ω

This configuration creates a standard zone stereo speaker output. (30W @ 8Ω/50W @ 4Ω)

1. **Stereo/Bridged Switch** - Set to the Stereo position.
2. **8Ω/4Ω-70V/100V Switch** - Set to the 8Ω/4Ω position.
3. **Speaker Connections** - Connect the wire from the right speaker - terminal to the right 4/8Ω - terminal as shown in: **Stereo 4/8Ω Connection**. Connect the wire from the right speaker + terminal to the right 4/8Ω + terminal as shown in: **Stereo 4/8Ω Connection**. Repeat for the left channel speaker.
4. **Zone Line IN** - Connect the L & R line level OUT on the zone audio source to the appropriate zone L & R LINE IN.

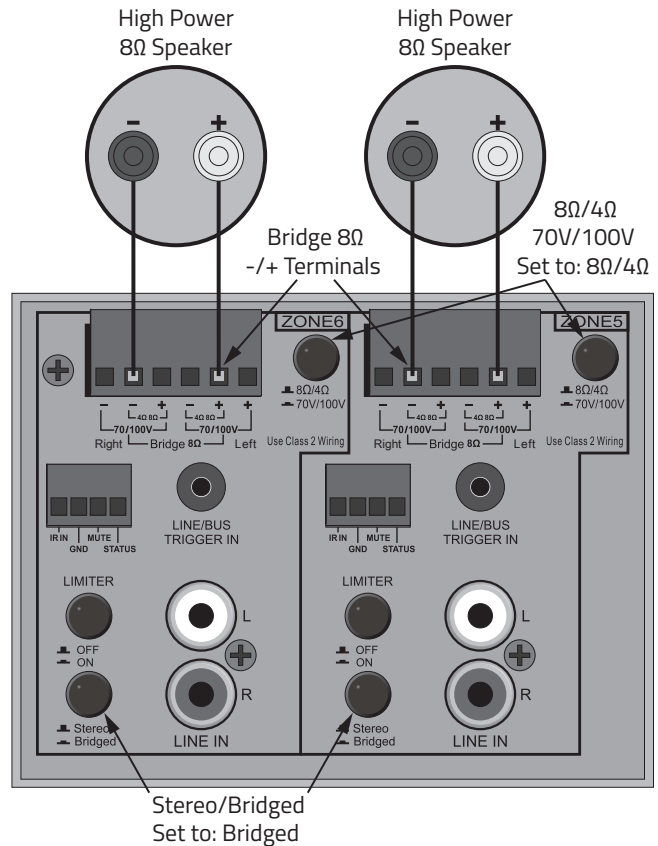

Bridged 8Ω Connection

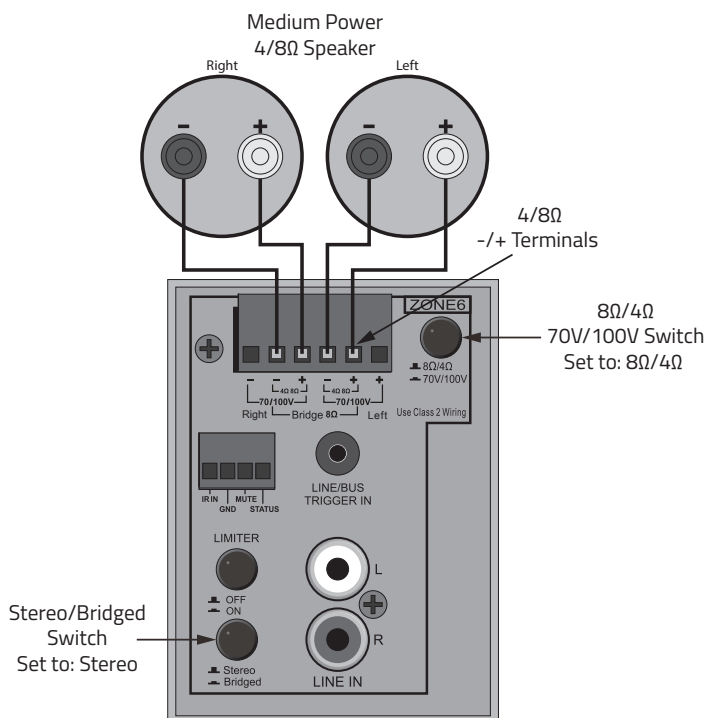

Stereo 4/8Ω Connection

Connections

70V/100V

This configuration creates a stereo 70V speaker zone. (30W/channel) A 70V/100 V system utilizes speakers with special taps that set the wattage/volume of each speaker.

70V/100V speaker system are wired using a daisy-chain configuration where the amp feeds a speaker, then that speaker connects to the next speaker and so on.

When setting a IA-1250 zone for 70V/100V, be sure to accurately calculate the total wattage required and not exceed the IA-1250 70V/100V zone's output, 30W per channel in 70V/100V mode.

Typically 70V amp power requirement can be calculated by adding the total of the tap wattage set for all speakers to be connected to a 70V/100V zone and multiplying it by 1.2. This will allow roughly a 20% loss of efficiency, typical for this type of system.

If the total wattage exceeds 30 Watts for a 70/100V zone, reduce the load to any given zone by connecting 70V/100V speakers to multiple zones set to 70V/100V to safely distribute the load.

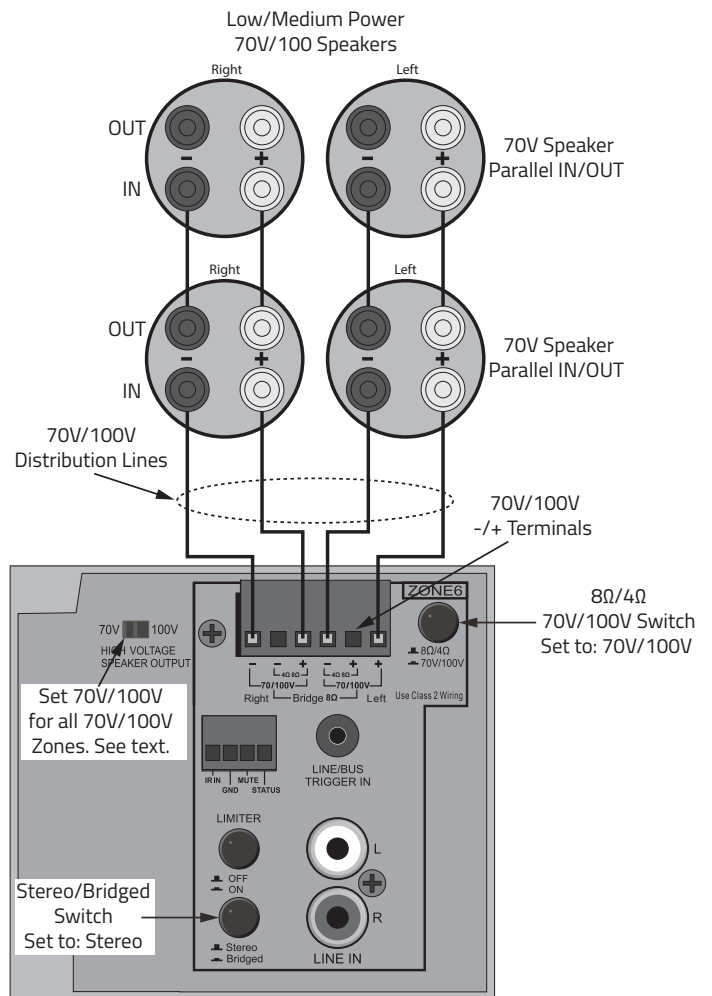

70V/100V Connection

- 1. 70V/100V High Voltage Speaker Output** - Set to 70V if IA-1250 AC Voltage Select switch is set to 110~120VAC. Set to 100V if IA-1250 AC Voltage Select switch is set to 220~240VAC. This setting will affect all zones set to 70V/100V.
- 1. Stereo/Bridged Switch** - Set to the Stereo position.
- 2. 8Ω/4Ω-70V/100V Switch** - Set to the 70V/100V position.
- 3. Speaker Connections** - Connect the right 70V distribution line +/- wires to the right 70V/100V +/- terminals as shown in: **70V/100V Connection**. If configuring stereo, Repeat for the left channel speaker.

Connect the right channel +/- distribution lines to the IN terminals on the first 70/100V speaker. Repeat for the left channel.

Connect the right/left channel +/- distribution lines to the OUT terminals on the first 70/100V speaker.

Connect the right/left channel +/- distribution lines to the IN terminals on the next 70/100V speaker.

NOTE 1: Speaker terminals may not be specifically marked IN/OUT.

NOTE 2: In a 70/100V system +/- polarity is not critical in same way as in a 4/8Ω system. But it is critically important that the connections be consistent, that is, plus to plus, minus to minus.

4. Zone Line IN - Connect the L & R line level OUT on the zone audio source to the appropriate zone L & R LINE IN.

Connections

Other Connections

...and this would be all the other stuff that needs to get connected...

Audio Connections

ZONE LINE IN

This connection is an input for a dedicated zone line-level audio source. If multiple line level audio sources are required in a zone, use an audio switch on the zone Line IN or use a multi-source, multi-zone controller if multiple audio sources are required in multiple zones.

- Line IN** - Using a quality, stereo audio RCA-RCA patch cable with gold ends, connect the L&R line level OUTs on the audio source to the L&R Line INs on the appropriate IA-1250 zone.

AUDIO BUS IN

This connection will distribute unbalanced line level audio to any zone set to 'Bus' with the Line/Bus Trigger IN.

NOTE: This is a mono unbalanced line level input. If connecting a stereo line level device, use an appropriate stereo to mono adapter as shown when making this connection.

- IN** - Connect the RCA to bare wire adapter to the Audio Bus IN +/-GND terminals as shown.
- Connect the Audio Bus IN Source to the RCA adapter. Use a stereo to mono adapter if connecting a stereo source.

NOTE: Polarity of RCA plugs/jacks is typically pin = signal, sleeve =GND.

AUDIO BUS OUT

This connection will send the unbalanced line level audio source connected to the Audio Bus IN to the Audio Bus IN on another IA-1250 or other audio amplifier.

- OUT** - Using either the RCA adapter or bare wire, connect the Audio Bus OUT +/-GND terminals on IA-1250 #1 to the Audio Bus IN +/-GND terminals on IA-1250 #2.

NOTE: Polarity of RCA plugs/jacks is typically pin = signal, sleeve =GND.

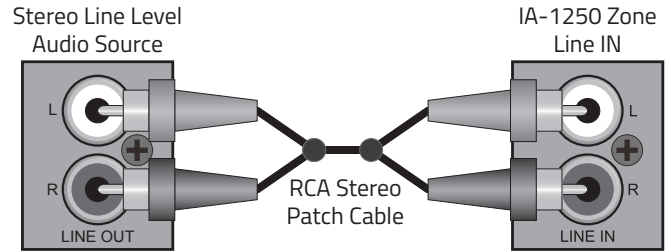

Zone Line IN Connections

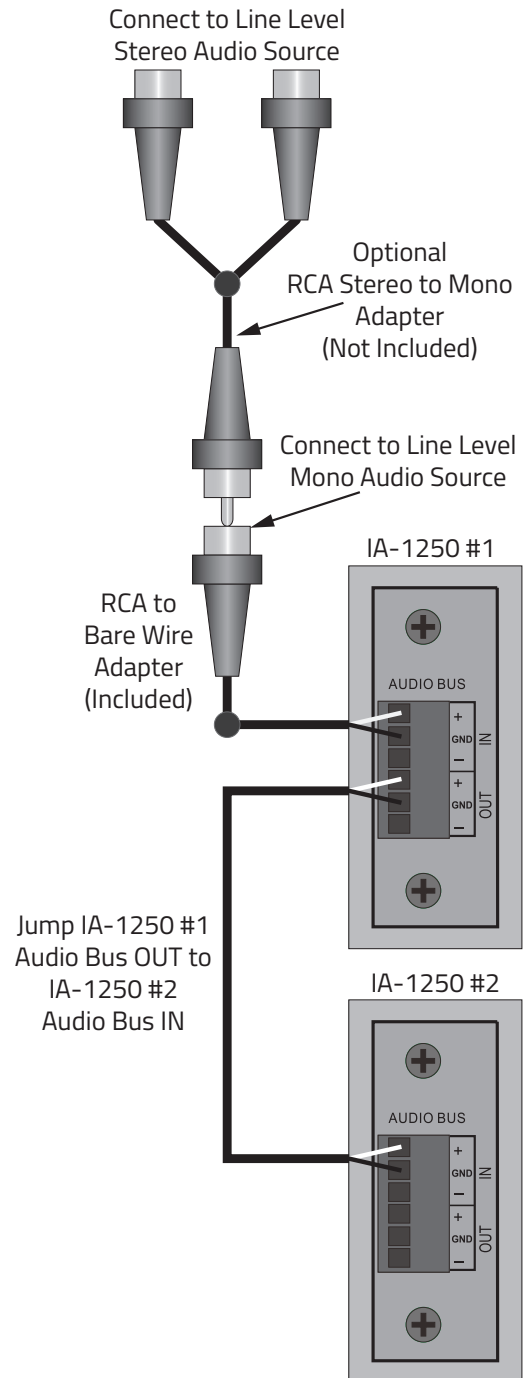

Audio Bus IN/OUT Connections

Connections

Control Connections

ZONE IR IN

This connection allows IR control of the connected zone for zone power, volume, mute, Line/Bus, etc using the commands from the IA-1250 IR Remote and a connected IR control system.

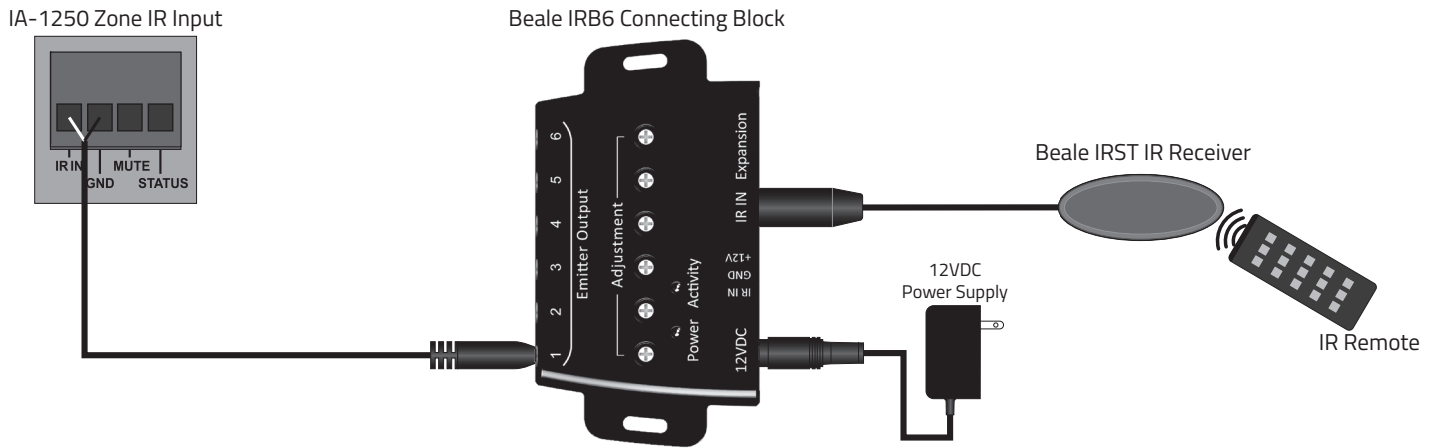

Zone IR Connections

- 1. IR/GND -** Using a 2-circuit 3.5mm mini plug cable, connect the IR Emitter OUT of an Xpress or other IR control system to the IR IN and GND terminals on the appropriate IA-1250 zone. Connect the white stripe (tip) to IR IN, connect the black (sleeve) to GND.

NOTE: Polarity of IR Emitter 3.5mm plugs/jacks is typically tip = signal, sleeve =GND.

Connections

ZONE MUTE

This connection allows voltage control of zone mute. Applied voltage (+3 to +30VDC @1mA) will mute the zone speaker output. When the voltage is cut, zone speaker output is restored.

- MUTE/GND** - Using a 2-conductor stranded, non-shielded cable, connect +DC voltage and GND from the trigger device to the MUTE and GND terminals on the appropriate IA-1250 zone. Connect +VDC to MUTE, connect GND to GND.

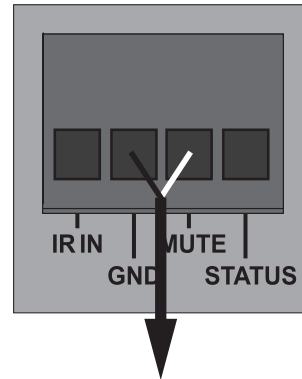

To +V/GND
on Trigger Device

Zone Mute Connection

ZONE STATUS OUT

This connection provides a +12VDC 1mA zone control output that can be used to trigger zone specific, voltage controlled devices. When an IA-1250 zone is ON, this connection will output a +12VDC control voltage. When the zone is OFF the control voltage is 0.0VDC

- Status/GND** - Using a 2-conductor stranded, non-shielded cable, connect STATUS (+DC voltage) and GND from the IA-1250 zone to the Control IN (+VDC) and GND terminals on the device to be controlled. If the controlled device uses a jack, please refer to the product's owner's manual to confirm the polarity of the connection.

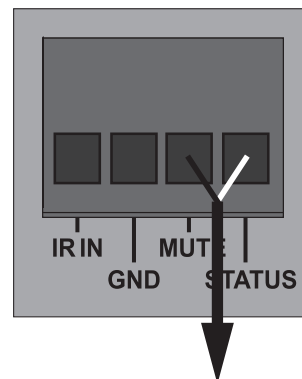

To +V/GND
on Voltage Controlled Device

Zone Voltage Control Connection

ZONE LINE/BUS TRIGGER IN

This connection provides a voltage trigger to switch the zone audio input from Line IN to Audio Bus IN. When there is no voltage applied, the zone audio input is zone Line IN. When voltage is applied the zone audio input will switch to Audio Bus IN...an excellent option for audio page override.

- Line/Bus** - Using a 2 circuit 3.5mm mini plug, connect the voltage trigger to the appropriate zone Line/Bus Trigger IN. Connect +12VDC from the trigger device to the striped wire (tip). Connect GND from the trigger device to the unmarked wire (sleeve).

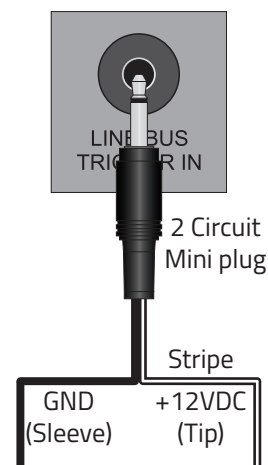

Zone Line/Bus Trigger Connection

Connections

MASTER CONTROL IN

This connection allows voltage control of IA-1250 ON/OFF. Applied voltage (+3 to +30VDC @1mA) will turn the amp ON. When voltage is cut, the amp will turn OFF. (OFF, not Standby.)

NOTE: The Power Switch must be in the OFF position when using this feature. With this feature the IR and RS232 controls will not turn a zone ON or have any other control unless proper voltage is applied to the Control IN.

- 1. Master Control IN** - Using a 2 circuit 3.5mm mini plug, connect the voltage trigger to the Master Control IN. Connect +3 to +30VDC @1mA from the trigger device to the striped wire (tip). Connect GND from the trigger device to the unmarked wire (sleeve).

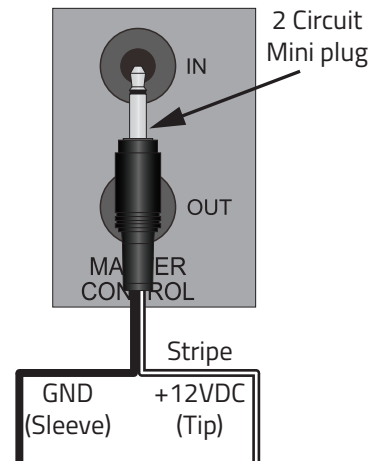

Master Control IN Connection

MASTER CONTROL OUT

This connection provides a voltage control OUT that can be used for triggering voltage controlled system devices that need to be turned ON when any IA-1250 zone is active. When any IA-1250 zone is ON, the Master Control OUT will output +11.5VDC@1mA-10VDC@5mA. If all zones are OFF, the Master Control OUT will output 0.0VDC.

- 1. Master Control OUT** - Using a 2 circuit 3.5mm mini plug, connect the IA-1250 Master Control OUT to the voltage controlled device(s). Connect the striped wire (tip) to +12VDC on the controlled device. Connect GND the unmarked wire (sleeve) to GND on the controlled device.

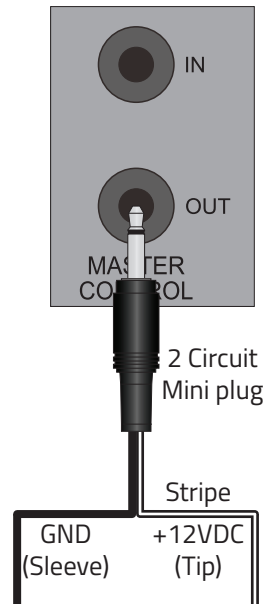

Master Control OUT Connection

RS232 I/O

This connection provides a two-way communication terminal for control/status feedback of the IA-1250 from/to an automation system or other appropriately capable device.

- 1. RS232** - Using a DB9 Patch Cable, connect the IA-1250 RS232 Terminal to an appropriate RS232 terminal on an automation system controller or other device. IA-1250 RS232 DB9F pin-out is as shown. Please refer to the control device's owner's manual to confirm RS232 terminal pin-out.

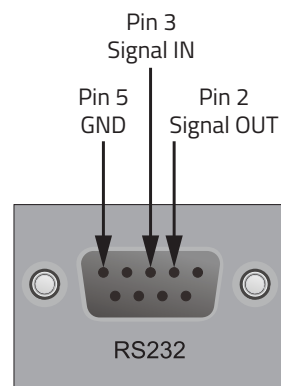

RS232 Terminal Pin-Out

Settings

This section covers all of the settings that need to be set correctly in order for the IA-1250 to function properly and not blow up...now that we have your attention...

70V/100V HIGH VOLTAGE SPEAKER OUTPUT

Sets all zone speaker connections configured for 70V/100V to either 70 volts or 100 volts. This switch is used in conjunction with both the AC Voltage Select switch and the zone 8Ω/4Ω-70V/100V switch setting.

All zones set for 70V/100V will be affected by the 70V/100V High Voltage Speaker Output switch setting, so be sure to have 70V/100V speakers properly connected and configured when changing this setting.

1. **70V/100V High Voltage Speaker Output** - Set to 70V if IA-1250 AC Voltage Select switch is set to 110~120VAC. Set to 100V if IA-1250 AC Voltage Select switch is set to 220~240VAC. This setting will affect all zones set to 70V/100V.

8Ω/4Ω-70V/100V ZONE SETTING

This switch selects the zone amplifier 8Ω/4Ω-70V/100V output mode. The setting is specific to the connection and type of speakers used in a given zone. See section: **Speaker Connections** for configuration information.

STEREO/BRIDGED ZONE SETTING

This switch selects the zone amplifier Stereo/Bridged output mode. The setting is specific to the connection and type of speakers used in a given zone. See section: **Speaker Connections** for full information on different configurations.

LIMITER

This switch activates a -20dB audio limiter that will help reduce the level of accidental loud noises and clipping distortion for both channels in a given zone.

1. **Limiter** - The Limiter is OFF with the switch in the OUT position. The Limiter is ON with the switch in the IN position .

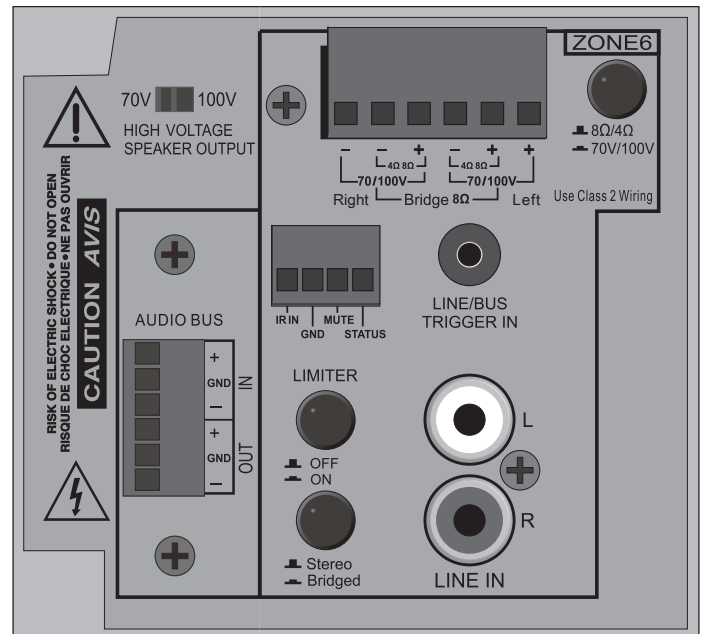

**70V/100V Speaker Output System Setting
8Ω/4Ω-70V/100V Zone Setting
Stereo/Bridged Zone Setting
Limiter Zone Setting**

Settings

REMOTE BYPASS

The Remote Bypass switch allows/prevents IR and RS232 control by zone. When the switch is in the ON position (bypass zone) the zone will not respond to IR or RS232 commands. When the switch is in the OFF position, (do not bypass zone) the zone will respond to IR and RS232 commands.

- 1. Remote Bypass** - Set to ON position to block IR and RS232 commands from controlling the selected zone. Set to OFF position to allow IR and RS232 control of the selected zone.

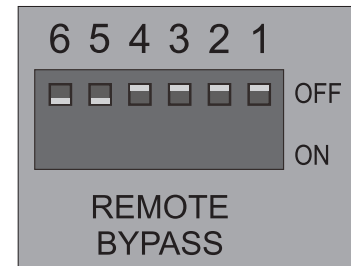

Remote Bypass Switch

VOLTAGE SELECT/FUSE

This switch sets the voltage to the AC Mains. Be sure to check AC voltage at the geographic location where the IA-1250 will be installed.

- 1. Voltage Select** - Set as appropriate for geographic location. NEVER CHANGE THIS SWITCH SETTING WHILE THE IA-1250 IS CONNECTED TO AC POWER!
- 2. Fuse**- Confirm that the proper fuse is installed for the selected AC Voltage. If set to 220V-240V/50Hz use a T5.0AL/250V fuse. If set to 110V-120V/60Hz use a T10.0AL/250V fuse.

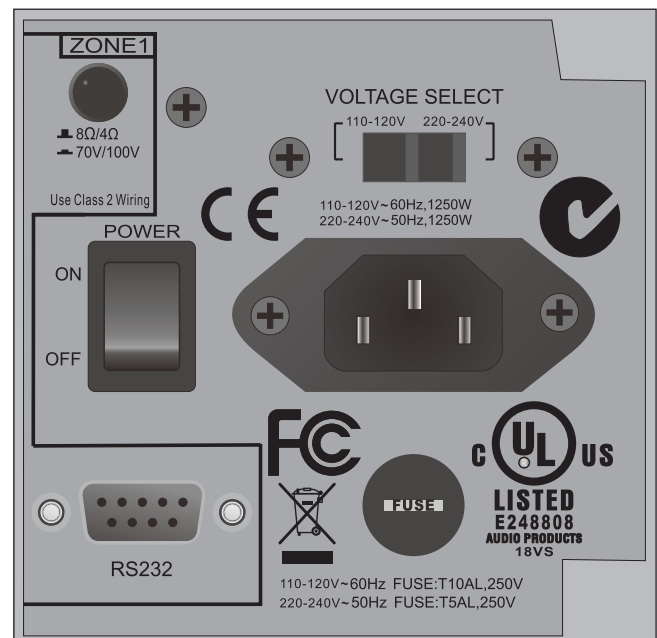

AV Voltage Select/Fuse

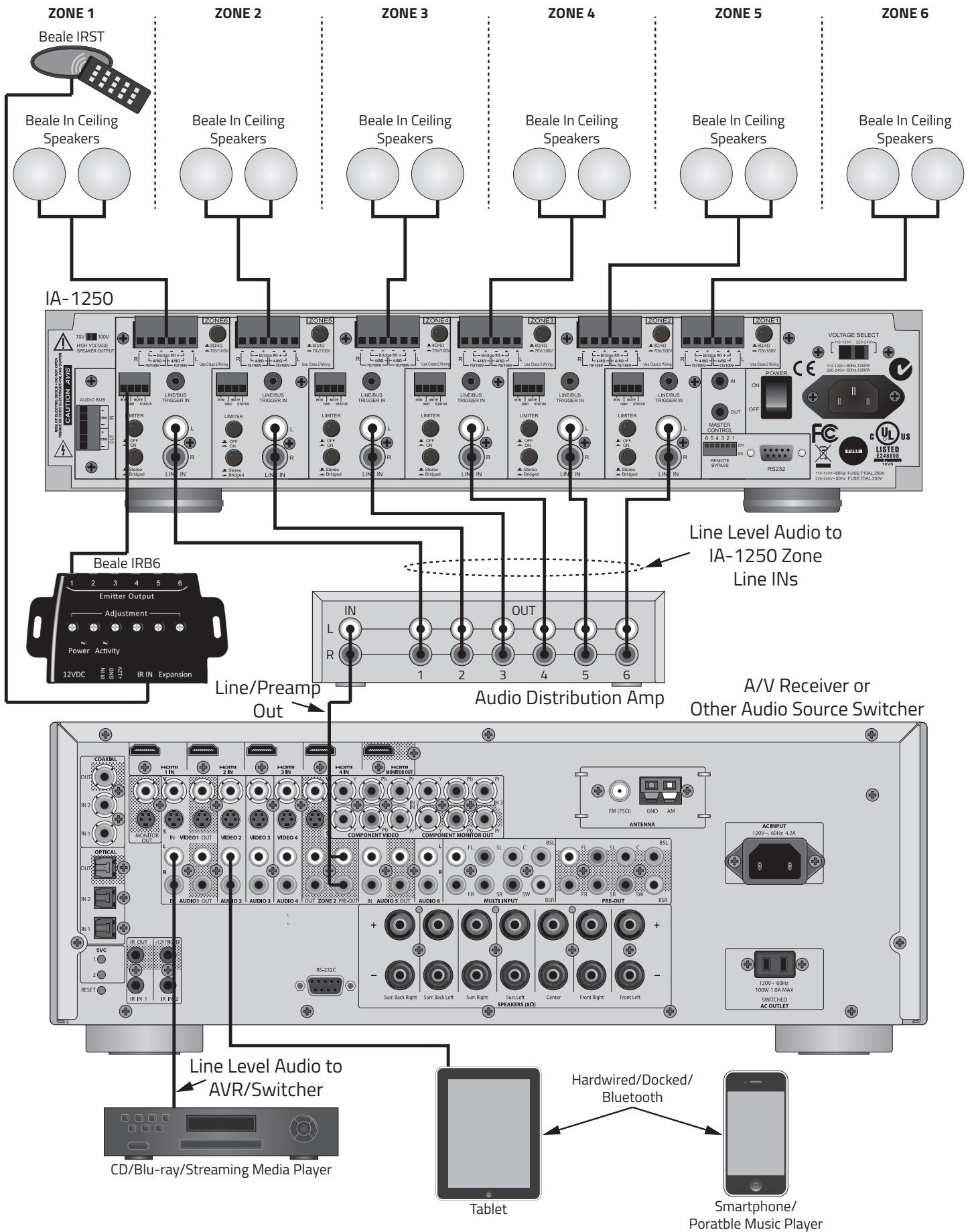

Typical, but not only, IA-1250 System Application

Operation

As with everything else about the IA-1250, how it is controlled is dependent upon how it is being used. Three basic modes will be explained: Voltage controlled, IR controlled and RS232 controlled.

There are of course, variations on these three basic control modes that can utilize some options from the other modes. An attempt to detail every option would probably be more confusing than useful, so look for the features that fit a given application, and then configure the IA-1250 appropriately.

VOLTAGE CONTROLLED

This mode would typically be used when the IA-1250 is being used purely as a multi-channel power amp with a multi-zone controller or preamp. That is, there would typically be no control of volume, mute or any other functions other than amp ON/OFF.

In this mode the IA-1250 will be turned ON with a control voltage from the multi-zone controller or preamp to the Control IN jack. The IA-1250 zone amps will output audio content as selected by the zone controller or preamp at levels set by the zone controller or preamp. Zone audio can also be switched to the Audio Bus IN using a voltage trigger on any zone(s) where audio paging or other temporary 'Bus' audio source may be desirable.

The IA-1250 will turn OFF when the control voltage to the IA-1250 Control IN from the multi-zone controller or preamp is cut.

Setup

Connect the IA-1250 Control IN jack to a voltage control OUT on the multi-zone controller or preamp. See section Connections/Control IN for additional information.

NOTE: In this application it may be desirable to connect an IR system to the individual zones to set zone audio levels relative to the multi-zone controller or preamp to set max output levels. This can also be done using a computer with a USB to Serial adapter via RS232. (These connections would be for setup only.)

Operation

There would not be any user specific control of the IA-1250 in this application.

IR CONTROLLED

This mode would typically be used when the IA-1250 is being used with a single audio source being fed to all IA-1250 zones, (as shown in the illustration on the opposite page) or when each IA-1250 zone has a dedicated audio source. The IA-1250 IR Remote would be used to turn a zone ON/OFF, adjust volume, mute and tone controls.

NOTE: The Remote Bypass switch can be used to allow or not allow (bypass) IR (and/or RS232) control of any/all zone(s).

All of the following assumes control from a local zone with a connected IR receiver as shown in the illustration on the opposite page. The IR control system can also be used to control the audio source(s) and other IR controlled devices. Each zone would require a dedicated IR system or use of an IR zone controller with dedicated zone IR IN/OUTs.

Operation

- 1. ON/OFF** - Press the Power button on the IA-1250 IR Remote to turn the zone ON. Press again to turn the zone OFF.
- 2. Bus/Line** - Press the Bus button to select the source connected to the IA-1250 Audio Bus In (if used). Press the Line button to select the source connected to the local zone Line IN.
- 3. VOLUME/MUTE** - Press the Volume UP/DOWN buttons to increase/decrease zone volume. Press the Mute button once to mute local zone audio. Press again to un-mute local zone audio.
- 4. TREBLE/BASS** - Press the Treble/Bass +/- buttons to adjust local zone treble/bass.
IMPORTANT NOTE - The only way to accurately reset treble/bass 'flat' (audio signal pass-through) is with RS232 commands! There are no treble/bass 'flat' IR commands!
- 4. BALANCE LEFT/RIGHT** - Press the Balance L/R +/- buttons to adjust local zone left/right balance.
IMPORTANT NOTE - The only way to accurately reset left/right 'center' (audio signal pass-through) is with RS232 commands! There is no balance 'center' IR command!

BUS AUDIO IN - Zone audio can also be switched to the Audio Bus IN using a voltage trigger on any zone(s) where audio paging or other temporary 'Bus' audio source may be desirable.

RS232 CONTROLLED

This mode would typically be used when the IA-1250 is being used in a more sophisticated system with advanced control (RS232) capabilities. All of the functionality detailed in the Voltage Controlled and IR Controlled can still be incorporated into a system with RS232 control, but RS232 control adds even more flexible and precise control. The IA-1250 can respond to specific RS232 commands and send status back to a controller or display for verification of zone settings.

Use the tables on the following pages to configure an appropriate RS232 controller with commands for Zone ON/OFF, Volume/Mute, Input, Treble/Bass, etc. Commands can be discreet ON/OFF, ramping volume or specific audio levels, incremental treble/bass or step increase/decrease, specific input select or toggle input.

The IA-1250 RS232 section can automatically return Zone Status Updates that will show any changes to zone settings made by the IR remote or voltage triggers as individual changes or complete zone status.

Queries can also be configured to ask and confirm specific zone settings including all RS232 controlled functions and zone status.

Specific control and functionality may vary from system to system, given the types of controllers used and system configuration, but overall RS232 functionality should be pretty straight forward for anyone familiar with this type of setup.

RS232 Commands

Want to control the IA-1250 via RS232? First, connect the amp to an appropriate RS232 controller per the connection instructions in Control Connections/RS232I/O. Then use this section of alpha-numeric mumbo jumbo (RS232 Commands) to program the controller for IA-1250 RS232 control by zone. Then, if you want to know what's going on in a specific zone, use the next section of alpha-numeric mumbo jumbo (RS232 Queries) to get feedback on various zone statuses. But first, a few technicalities worth noting...

Baud: 9600

Data Bits: 8

Parity: None

Stop Bits: 1

Flow Control: None

IA-1250 RS232 COMMANDS		
NAME	COMMAND	REMARKS
Zone Power	!{z#}PR{0/1}+	To turn on Zone 2: !2PR1+
		To turn off Zone1: !1PRO+
Zone Power Toggle	!{z#}PT+	
Zone Volume	!{z#}VO{v#}+	
Zone Vol. Inc.	!{z#}VI+	
Zone Vol. Dec.	!{z#}VD+	
Zone Input Select	!{z#}IS{0/1}+	To select BUS: !2IS0+
		To select LINE: !2IS1+
Zone Input Select Toggle	!{z#}IT+	
Channel Input Select	!{c#}CS{0/1}+	To select BUS: !2CS0+
		To select LINE: !2CS1+
Channel Input Select Toggle	!{c#}CT+	
Mute	!{z#}MU{0/1}+	To mute Zone 3: !3MU1+
		To unmute Zone 4: !4MU0+
Mute Toggle	!{z#}MT+	

RS232 Commands

IA-1250 RS232 COMMANDS		
NAME	COMMAND	REMARKS
Treble	!{z#}TR{bt#}+	
Treble Increment	!{z#}TI+	
Treble Decrement	!{z#}TD+	
Bass	!{z#}BS{bt#}+	
Bass Increment	!{z#}BI+	
Bass Decrement	!{z#}BD+	
Balance	!{z#}BA{b#}+	
Balance Step Left	!{z#}BL+	
Balance Step Right	!{z#}BR+	
Zone Activity Auto Update	!ZA{0/1}+	Enable/Disable Auto Update of the Zone Information when Zone Activity is Detected. (See below for format of the output.)
Zone Max. Volume	!{z#}MX+	Sets current volume setting as a maximum desired volume level for a specific zone. The volume is first adjusted to what is desired as a maximum level. The Zone Max. Volume command is then activated to lock in the setting. This acts as a volume limiter for the system

Where:

{z#} - Zone Number. Range is 1..6

{c#} - Channel Number. Range is 1..12

{0/1} - Either 0 (zero) or 1 (one). 0 - Off, 1 - On.

{v#} - Volume Setting. Range is 0..38. See VOLUME LEVEL table below.

{bt#} - Bass/Treble Setting. Range is 0..14. See BASS/TREBLE LEVEL table below.

{b#} - Balance Setting. Range is 0..63. See BALANCE LEVEL table below.

RS232 Queries

IA-1250 RS232 QUERIES				
NAME	QUERY	RESPONSE	EXAMPLE RESPONSE	EXPLANATION
Zone Volume	?{z#}VO+	?{z#}VO{v#}+	?4VO49+	Zone 4 is currently at volume level 49.
Channel Volume	?{c#}CH+	?{c#}CH{v#}+	?4VO49+	Channel 4 is currently at volume level 49.
Mute	?{z#}MU+	?{z#}MU{0/1}+	?8MU1+	Zone 8 is currently muted.
Power	?{z#}PR+	?{z#}PR{0/1}+	?8PR1+	Zone 8 is currently powered on.
Input Select	?{z#}IS+	?{z#}IS{0/1}+	?8IS1+	Zone 8 input selection is on LINE.
Treble	?{z#}TR+	?{z#}TR{bt#}+	?1TR7+	Zone 1 currently has a treble value of 7 (flat)
Bass	?{z#}BS+	?{z#}BS{bt#}+	?1BS7+	Zone 1 currently has a bass value of 7 (flat)
Balance	?{z#}BA+	?{z#}BA{t#}+	?2BA31+	Zone 2 currently has a balance value of 31 (even)
Zone Activity Auto Update	?ZA+	?ZA{0/1}+	?ZA1+	Zone Activity Auto Update is enabled
Zone Status	?{z#}ZS+	See Below	See Below	Returns the complete status of the Zone.

Where:

{z#} - Zone Number. Range is 1..6

{c#} - Channel Number. Range is 1..12

{0/1} - Either 0 (zero) or 1 (one). 0 - Off, 1 - On.

{v#} - Volume Setting. Range is 0..38. See VOLUME LEVEL table below.

{bt#} - Bass/Treble Setting. Range is 0..14. See BASS/TREBLE LEVEL table below.

{b#} - Balance Setting. Range is 0..63. See BALANCE LEVEL table below.

RS232 Queries

Zone Activity and Zone Status

ZA – Zone Activity Auto Update Enable Command. Format - !ZA{0/1}+

ZS – Zone Status Query. Format - ?{z#}ZS+

Zone Activity Auto Update Enable Command

The Activity Update will cause the system to send out the complete Zone State whenever something in the zone changes. The State string will be sent out one second after activity in the zone stops. Also, the Metadata will be sent out whenever it changes.

Zone Status Query

The Zone Status Query will cause the system to send out the full Zone State string along with the Zone Metadata string(s), for the specified zone.

IMPORTANT NOTE: Also, use the highest baud rate that the receiving system can support.

When the Amplifier sends out complete Zone Status, (either due to an explicit query or due to an Auto Update, the data is formatted a bit differently than the standard responses to a Command or Query.

All of the Zone Info / Zone Status output lines will begin with the character '#' (the sharp, or number sign).

The format of the Zone State is:

#{z#}ZS VO{v#} PO{0/1} MU{0/1} IS{0/1}+

An example:

#6ZS VO8 PO1 MU0 IS0+

This line tells us the following info about Zone 6:

Zone Volume – 8

Power – On

Mute – Off

Input Select – Bus

RS232 Settings

IA-1250 VOLUME LEVEL SETTINGS	
IA-1250 SETTING	ATTENUATION LEVEL
38	0
37	-1.25
36	-2.50
35	-3.75
34	-5.00
33	-6.25
32	-7.50
31	-8.75
30	-10.00
29	-11.25
28	-12.50
27	-13.75
26	-15.00
25	-16.25
24	-17.50
23	-18.75
22	-20.00
21	-21.25
20	-22.50
19	-23.75
18	-25.00
17	-27.50
16	-30.00
15	-32.50
14	-35.00
13	-37.50
12	-40.00
11	-42.50
10	-45.00
9	-47.50
8	-50.00
7	52.50

RS232 Settings

IA-1250 VOLUME LEVEL SETTINGS	
IA-1250 SETTING	ATTENUATION LEVEL
6	56.25
5	-60.00
4	-63.75
3	-67.50
2	-71.25
1	-75.00
0	-78.75

IA-1250 TREBLE/BASS LEVEL SETTINGS	
IA-1250 SETTING	LEVEL (+/-dB)
14	+14
13	+12
12	+10
11	+8
10	+6
9	+4
8	+2
7	0
6	-2
5	-4
4	-6
3	-8
2	-10
1	-12
0	-14

IA-1250 LEFT/RIGHT BALANCE SETTINGS		
IA-1250 SETTING	LEFT SPEAKER +/- ddB	RIGHT SPEAKER +/-dB
0	0	Mute
1	0	-37.5
2	0	-36.25
...
29	0	-2.5
30	0	-1.25
31	0	0
32	0	0
33	-1.25	0
34	-2.5	0
...	...	0
62	-37.5	0
63	Mute	0

Specifications

Audio Sections

Continuous Output Power	30W per channel 8ohms at 1kHz THD 0.1%
	50W per channel 4ohms at 1kHz THD 0.1%
	100W Bridged 8ohms at 1kHz THD 0.1%
	30W per channel 70V/100V at 1kHz THD 0.1%
Total Harmonic Distortion.....	0.1% @ 10W
Signal-to-Noise Ratio	90dB A-Weighted 1kHz
Channel Separation.....	65dB 1kHz
Frequency Response	20Hz to 20kHz+/- 1dB
Input Sensitivity	600mV @ 30W
Tone Control	Bass 100Hz +/- 12dB
Treble.....	10k Hz +/- 12dB
Line Input Impedance.....	47 k-Ohm

Voltage Control Sections

Master Control IN	+3 to +30VDC @1mA
Master Control OUT	+11.5VDC@1mA-10VDC@5mA
Zone Line/Bus Trigger IN.....	+12VDC
Zone Mute Trigger IN.....	+3 to +30VDC @1mA
Zone Status OUT.....	+12VDC 1mA

RS232 Section

Baud	9600
Data Bits.....	8
Parity.....	None
Stop Bits.....	1
Flow Control.....	None

General

Rack mounting requirements	19 inch rack width, 2U rack height
Power Requirements.....	115VAC 60Hz 10A/ 230VAC 50Hz 5A
Dimensions (Not including rack ears).....	16.9"W x 3.5"H x 16.4"D (430W x 88H x 416D mm)
Weight.....	48.4lbs (22 kg)

Limited Warranty

All in-wall, in-ceiling, outdoor speakers, volume controls, and freestanding loudspeakers have a Lifetime Limited Warranty. This warranty includes lifetime parts and repair on components. Powered subwoofers and Xpress amplifiers have a two (2) year limited warranty. This warranty includes two (2) year parts and repair labor on components. Xpress obligation under this warranty is limited to repairing or replacing any component found defective in material or workmanship under normal conditions of use. This warranty shall not apply to products which have been abused, modified, disassembled, or repaired by anyone other than Xpress or one of its appointed service centers. Products to be repaired under this warranty must be returned to the factory or designated service center with all transportation and insurance charges pre-paid.

IMPORTANT: This warranty is ONLY valid if the product is purchased through an Xpress Dealer. Proof of purchase may be required.

Note: It is the policy of Xpress to continuously incorporate improvements into our products. All specifications, warranty terms, and prices are subject to change without notice.

Notes



XPECT MORE

Beale Xpress
122 Gayoso Street, Suite 101
Memphis, TN 38103
Phone: 844.489.2700 Fax: 901.205.0900
www.bealexpress.com
©2015 Beale Street Audio

